

RM85

Resistance Meter System

Introduction

The RM85 Resistance Meter system is designed for rapid area or vertical profile measurements. Targets can be archaeological, environmental, forensic, utility, geological or military. There are two models available: BASIC and ADVANCED. The ADVANCED model has a wider range of currents (up to 10mA), wider range of operating frequencies (17.5 to 142.5 Hz in 13 steps plus user defined frequency) and higher output voltage (100V) to allow operation in more demanding situations. A half current setting (Compliance Boost) allows the user to optimise signal to noise ratio against probe contact resistance. The BASIC is upgradable to the ADVANCED model.

Both models can be used in Probe Mode where conventional probes are inserted into the ground for area mapping or vertical profiling. An optional internal multiplexer card is available for either BASIC or ADVANCED models. This allows the RM85 to automatically configure and log data from multi-probe arrays – the number of measurement lines increases from the standard 4 up to 8.

The ADVANCED model can also be used in Wheel Mode where it is mounted on an MSP25 or MSP40 Mobile Sensor Platform (with spiked wheels in place of the probes) for fast, detailed resistance mapping and, optionally, simultaneous magnetic surveys with an FM256. There is also a GPS logging option for the ADVANCED model that records GPS position (NMEA string) with each reading (user supplied GPS unit) and provides real time monitoring / feedback of GPS signal Quality and DOP. A real time resistance reading output is available for the ADVANCED model for connecting to external logging systems.

Data can be downloaded using either a USB or RS232 connection. An expansion port can connect and communicate with external modules such as the interface for a wheeled array. There is an external access compartment for the NiMH battery pack with fast charging and LED status. For special requirements an optional external power supply adapter can be fitted to the battery compartment so the RM85 can be powered from an external 12V battery for greatly extended operating time.

Probe Mode and Multiplexing

When used with PA20, PA5, PA3 or PA1 probe arrays, the RM85 can log data with configurations such as Twin, Pole-Pole, Double-Dipole, Wenner, Schlumberger, Gradient etc. The optional internal multiplexer card allows the RM85 to configure and control logging of data from multi-probe arrays on the PA20. The user can define 8 different programmed multiplex sequences, each with 16 configurations or sequences and accessing up to 8 probes (depending on the probe array). Readings are logged manually, or automatically by a special current sense circuit - insertion of the probes triggers a measurement or multiplex sequence. The RM85 has improved noise rejection capability whilst providing much faster speeds compared to an RM15 - survey time can be almost halved for Twin arrays, especially when multiplexed. This is due to changes to the multi-pole measurement filters, a wider range of operating frequencies, a wider range of Auto-Log delays times, and the addition of Speed Boost and Insertion Delay settings. As the reading settles Speed Boost logs data at an earlier but predictable part of the waveform. Insertion Delay allows the user to set a time to get all the probes correctly inserted into the ground and then to use a fast Auto-Log Delay time for the multiplex steps; this can be useful in dry conditions.

Wheel Mode

When mounted on an MSP25 or MSP40 Mobile Sensor Platform, resistance data can be collected much faster and at higher spatial resolution than is practical with conventional probes arrays. For example, when the MSP25 is configured as a square array, alpha, beta and gamma and GPS data can be collected at a sample interval of 0.25m at a rate of better than 0.6s/m; alpha, beta and GPS can be collected at 0.3s/m. Wheel mode multiplexing can also be programmed by the user, including Twin measurements. If an FM256 is added to the MSP25 or MSP40, simultaneous gradiometer data can be collected at 1, 2 or 4 times the RM85 sample interval, triggered by the RM85. Logging of readings can be triggered either under timer control or by distance encoder pulses from an MSP25 / MSP40 wheel.

Data Logger

Readings are stored in flash memory using square or rectangular grids of dimensions 10, 20, 30, 40, 50 or 100m. Sample interval can be 1, 2, 4, 8 or 16 readings per metre. The data logger keeps track of, and displays, survey position for zig-zag and parallel traverses. Incorrect readings may be deleted singly, or as complete lines with one keystroke. A dummy reading or line of dummies can be inserted in place of physical obstacles with one keystroke. A mirror image dummy line completion key is also provided for zig-zag surveys when part of the standard grid cannot be surveyed. Memory size is: BASIC 2745600, ADVANCED 5491200 readings. With GPS reading capacity will be 164,000 readings, sufficient for 2ha at a 0.25m sample interval with an MSP25/40 system (alpha and beta measurements).

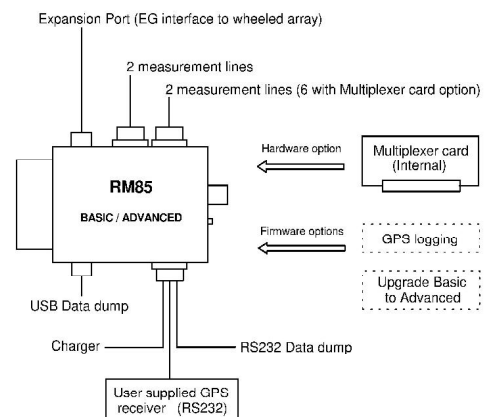

Probe Mode

PA20 Probe Array

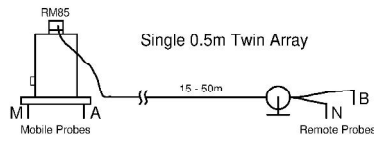
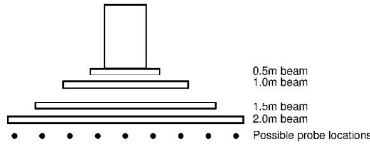

Log Mode = Single. One configuration only. eg 0.5m Twin



Log Mode = Parallel Twin. More than one configuration of the same type and probe separation, adjacent on the PA20 frame. For doubling speed or sample density.



Log Mode = Multiple. More than one configuration of either different type or different probe separation, usually with aligned centres. For building up pseudo-sections or for gaining depth information with different probe arrays.

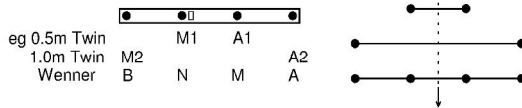

PA44 Probe Array (0.75m Square)*

Log Mode = Single. Alpha, beta or gamma.

Log Mode = Multiple. More than one 0.75m square configuration (alpha, beta or gamma). Both alpha and beta required for full directional information.

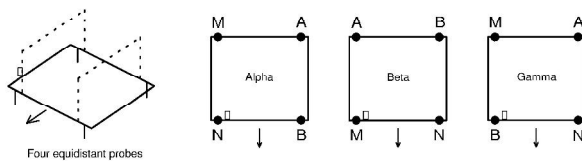

PA3 Probe Array

Log Mode = Single. One configuration only. eg Wenner, Double Dipole, Schlumberger. General purpose handprobe system with 50m cables used to configure arrays with large probe separations.

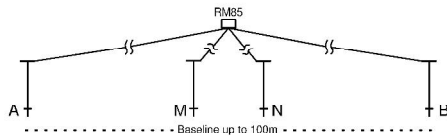

Wheel Mode (Advanced only)

MSP40 or MSP25 (0.75m Square)

Log Mode = Single. Alpha, beta or gamma.

Log Mode = Multiple. Alpha, Beta, Alpha + Beta, Gamma. Both alpha and beta required for full directional information. Optional triggering of mounted fluxgate gradiometer.

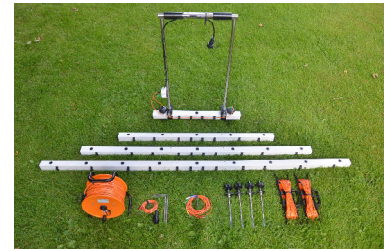
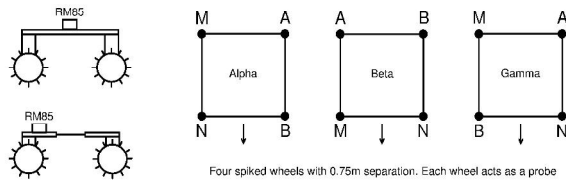

PA20 Multiprobe Array System

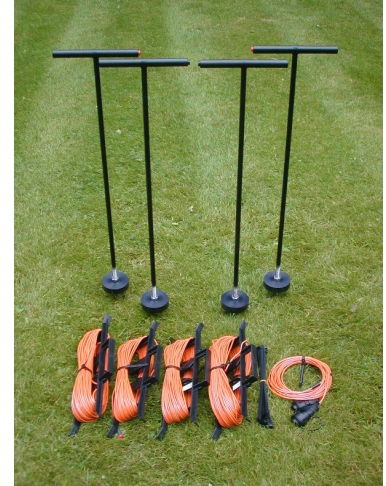

PA3 Probe Array



MSP25 Mobile Sensor Platform



RM85
Resistance Meter

Warning ! Do not touch electric fences with probes

Finish Line	Image Line	Dummy Log	Log
1	2	3	4
Enable Log	Clear Memory	Delete Line	Delete
↑ 5	← 6	→ 7	↓ 8
Cancel	Dump	Menu	Start
9	End Menu.	0	Enter



* Please note that the PA44 probe array shown in the system diagram above is a product under development and is not yet available.

RM85

Resistance Meter System

RM85

Resistance Meter System

Probe Mode Survey - Parallel Twin (3 probe)

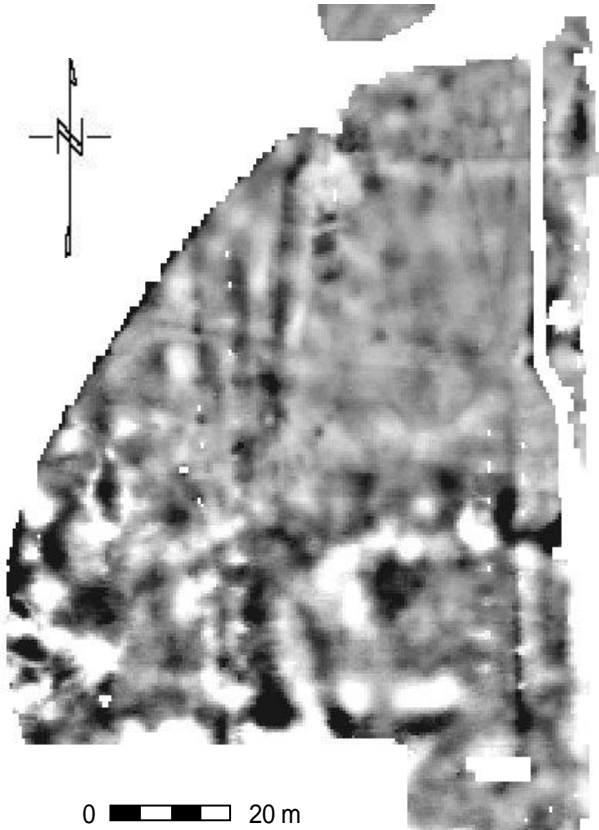

Crathes Castle 2012 (data reproduced courtesy of Rose Geophysics and NTS)

This survey was undertaken to locate any structural remains and garden features associated with Crathes Castle and its gardens. A PA20 probe array was configured as a 0.5m Parallel Twin (3 probes). Data was collected at 0.5m by 0.5m intervals with an auto-log delay time of 300ms. The large area, to the south of the castle, reveals the lines of former drives, possible outbuildings shown on earlier estate maps, garden compartments, small garden features and services. The smaller area, which is the croquet lawn SW of the castle, shows classic patterns of paths and parterres.

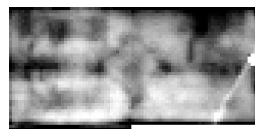

Raw

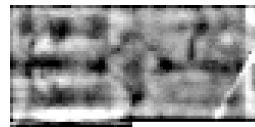

HPF 10x10

Plotting range +/- 1.5SD
Black is high resistance



Probe Mode Survey - Single & Multiple Twin (0.25, 0.5, 0.75, 1.0, 1.25, 1.5m)

The plots below show the results of a single 0.5m Twin survey, readings taken at 1m intervals using a 0.5m beam (left), and a second survey of the bottom right grid where multiple Twin readings of 0.25, 0.5, 0.75, 1, 1.25 and 1.5m were taken at 0.5m intervals using a 1.5m beam with 6 probes. Auto-log delay times were 200ms for the single, 300ms for the multiple survey. Geoplot was used to combine the multiple data into one strip and then create a stack of pseudo-sections from it. One pseudo-section was exported to Res2dinv for inversion (coloured plot below) - the multiple data set allows extraction of many pseudo-sections in both x and y directions.

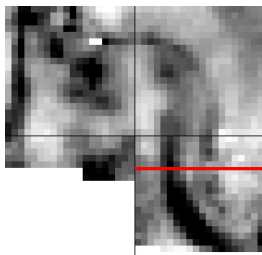

0 20 m

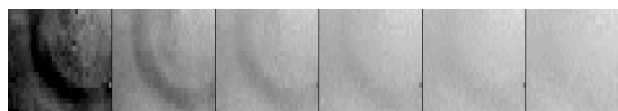

Multiple data set combined into one strip for data extraction

Pseudo-section line

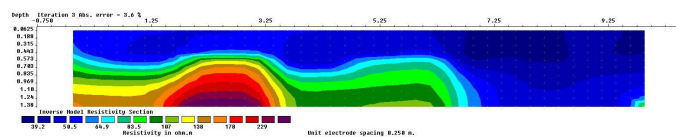

Inverted pseudo-section data using Res2dinv



Comparison between 0.5m Twin and high resolution 0.75m Square surveys

The data sets below were collected at our standard test area. This small area (3.5m by 10m) has a well defined wall running across the area. Comparative surveys were done with a 0.5m Twin array and a 0.75m multiplexed Square array (RM85 and MSP40). A traverse interval of 0.5m was used. Twin data was collected at 0.5m intervals; Square data (alpha and beta) was collected at a 0.25m intervals. The Square data (merged alpha and beta) and Twin data agree well, but the MSP40 Square array data provides much more detail, especially compared to what might be obtained from a standard 1m x 1m Twin survey. All plots made at +/- 2SD, black high resistance.



0.5m Twin array SI=TI=0.5m



0.75m Square (a+b) array



0.5m Twin array SI=TI=1m
(Interpolated from 0.5m Twin data)

Wheel Mode Survey - RM85 with MSP40, FM256 and GPS

The results shown below are of a combined resistance and gradiometer survey made at the walled garden of Kiplin Hall in the autumn of 2010. The garden was under grass and since there were plans to recreate the original garden layout a geophysical survey was undertaken to try and locate any features still remaining. A plan of 1893 shows a variety of features including paths, greenhouses and a pump and many of these were located in the survey.

An MSP40 Mobile Sensor Platform, with FM256 gradiometer mounted, was used to survey a large part of the garden. A prototype RM85 resistance meter with internal multiplexer card and Expansion Interface box was mounted on the MSP40. A Hemisphere A100 GPS unit with SBAS correction (10Hz) was mounted on the MSP40 for logging positional information with each reading. Some grids at the edges were surveyed using a conventional 0.5mTwin (RM15) and a single hand carried FM256. Geoplot was used for data processing.

The garden was divided into 20m grids with sample interval of 0.25m and traverse interval of 1m for both the MSP40 cart mounted RM85 and FM256. The RM15 data was collected at 1m intervals. The RM85 was configured to measure alpha, beta and gamma measurements every 0.25m in a zig-zag fashion. The wheel encoder system was used and the cart was pulled at about 0.8s per metre; each grid was surveyed in about 10 mins, equivalent to about 4 hours per hectare. This method of surveying 20m grids is inefficient in terms of lost survey time due to regular turning of the cart at line ends. Extending the traverse runs from 20m to 50m would translate into reducing the survey speed down to 2.9 hours per hectare.

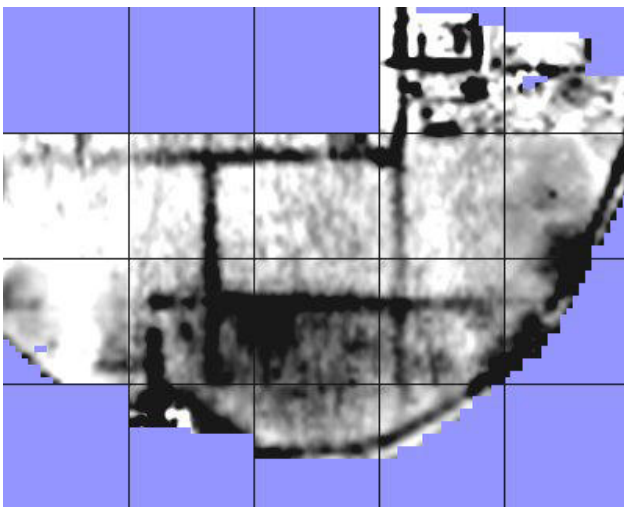

(left) Combined resistance data (7 to 13 ohms), Square and Twin
(right) FM256 gradiometer data (+/-5nT)
Neither data set GPS referenced in these plots

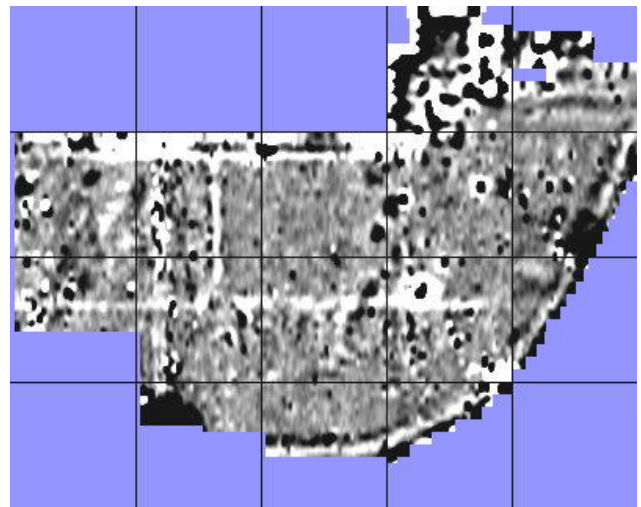

[Please see MSP25 data sheet and MSP25 Additional Information sheet for more recent survey examples](#)

RM85 
Resistance Meter System

RM85

Resistance Meter System

Typical Specifications ADVANCED model shown below. BASIC model has no Wheel mode or GPS option and only has 50V output, 1mA and 0.1mA current ranges, resistance ranges between 20 ohm and 20000 ohms, operating frequencies between 72.5 and 145 Hz.

TRANSMITTER Output voltage	50 / 100 V					
Constant current ranges (p-p)	10 mA	5 mA	1mA	0.5mA	0.1 mA	0.05mA
Maximum contact resistance (at 100 V)	10 Kohm	20 Kohm	100 Kohm	200 Kohm	1 Mohm	2 Mohm
RECEIVER Resistance ranges (manual)	2 ohm 20 ohm 200 ohm 2000 ohm 20,000 ohm					
Logged resolution (ohms)	0.0005	0.005	0.05	0.5	5	
Operating frequencies	17.5, 20, 22.5, 35, 40, 72.5, 80, 85, 90, 122.5, 137, 140, 142.5, User Defined Hz					
Probe mode Auto-Log Delay times	120, 200, 300, 450, 600, 800, 1000, 1200 ms (faster with Speed Boost)					
Probe mode measurement times with Speed Boost	120, 180, 250, 360, 435, 545, 780, 980 ms					
Insertion Delay times	0, 25, 50, 75, 100, 150, 200, 250, 300, 350, 400, 450, 500 ms					
Wheel mode Multiplex Delay times	50, 60, 70, 80, 90, 100, 110, 130, 150, 170, 200, 230, 330 ms					
High Pass Filter	Off, 0.05, 0.16, 1.6, 8, 13, 15 Hz (BASIC fixed at 13 Hz)					
GENERAL Memory capacity (flash)	ADVANCED 5,491,200 readings, BASIC 1,372,800, <u>no</u> GPS 164,000 readings <u>with</u> GPS (= 2ha at 0.25m SI, alpha+beta multiplex)					
Grid dimensions (length and width independant)	10, 20, 30, 40, 50, 60, 100m					
Sample Interval (SI)	0.0625, 0.125, 0.25, 0.5, 1m					
Communications	USB (2.0) and RS232 at up to 115200 baud (RS232 only for GPS)					
Weight (including batteries and multiplex card)	1.35 Kg					
Overall case dimensions	200 x 120 x 90 mm					
Charging time (NiMH battery pack)	4 hours, LED Status					

All specifications subject to change without prior notice.

Updating or upgrading an RM85 at a later date

If a multiplexer card is purchased at a later date this can be fitted by the user. When upgrading from BASIC to ADVANCED, we will supply a replacement microprocessor card. When upgrading to the GPS logging option at a later date you may be required to return the RM85 to Geoscan Research for a firmware update or we may be able to send a returnable firmware update kit to you.

Compatibility with existing RM15(-D) accessories

You can use existing arrays and most accessories with the RM85. The RM85 will be supplied with a mounting plate; new users will additionally require a rectangular bracket so it can be mounted on a new PA20. The AD1 adapter is no longer required for the PA5 and PA20 arrays. Existing adapters AD2 (gradient array) and AD3 (square, wanner, double-dipole array) will not be compatible and new versions, AD6 and AD5 will be required. If the RM85 has a multiplexer card then this can take the place of an AD3 adapter. The AD4 adapter (pole-pole array) is compatible with the RM85. A PA3 array will require one new adapter to interface with the RM85. A PA1 array will require an AD9 adapter.

Operation with an MSP40 and GPS

An RM85 ADVANCED with multiplexer card replaces the functions of the RM15(-D), DL256. An Expansion Interface box will be required in place of the MPX40. The GPS option only provides the logging facilities - a GPS unit is not included. To fit a GPS system, the MSP40 platform will need some mechanical customisation to suit your system.

Software with the RM85

You will require Geoplot 4.0 to take full advantage of the higher USB and RS232 baud rates of the RM85. The RM85 can also be configured to output data at 9600 baud in RM15(-D) format making it then compatible with Geoplot 3.0. You will need a future version of Geoplot 4.0 to process GPS data.

Geoscan Research
Heather Brae, Chrisharben Park,
Clayton, Bradford,
West Yorkshire BD14 6AE. UK



@GeoscanResearch

Tel : (+44) (0)1274 880568
Fax : (+44) (0)1274 818253
www.geoscan-research.co.uk
info@geoscan-research.co.uk



GEOSCAN

